

エアラインキット / Air Line Kit
AL - A1205

取扱説明書 / OPERATION MANUAL

日本語：P1 - P7 / English：P9 - P15

OM-K0654

Thank you for purchasing " AL - 1205 " Air Line Kit. This Air Line Kit will supply clean and dry cooling air to the Air Bearing Spindle and Turbine Motor. THIS AIR LINE KIT IS NOT A SUBSTITUTE FOR AN AIR DRYER. Read this and all the associated component Operation Manuals carefully before use. Always keep this Operation Manual in a place here a user can referred to for reference at any time.

1. CAUTIONS FOR HANDLING AND OPERATION

- Read these warnings and cautions carefully and only use in the manner intended.
- These warnings and cautions are intended to avoid potential hazards that could result in personal injury to the operator or damage to the device. These are classified as follows in accordance with the seriousness of the risk.

Class	Degree of Risk
⚠ WARNING	A safety hazard could result in bodily injury or damage to the device if the safety instructions are not properly followed.
⚠ CAUTION	A hazard that could result in light or moderate bodily injury or damage to the device if the safety instructions are not followed.

⚠ **WARNING**

① Handling

Connection to the Air Line Kit should be performed by a person with experience with compressed air and air compressors.

② Air Pressure

Compressed air is required. Do not exceed an air pressure of 1.0MPa at primary side and 0.85MPa at secondary side of the Air Line Kit.

③ Use of Clean Air

Do not use compressed air contaminated with chemicals, oil compounds, organic solvents, salinity or corrosive gasses in order to avoid damage to the device.

④ Connection of connection hose and supply air hose

Connect the input connection hose and supply air hose securely to avoid accidental disconnection during use. Input air pressure should never exceed 1.0MPa. Pressure exceeding 1.0MPa may cause the connection hose and supply air hose to rupture.

⑤ Inlet and Outlet Connections

Do not hit, impact or cause shock to the Inlet or Outlet Connector Connections. Never put undue stress or load on the Inlet or Outlet Connector Connections. Any damage to these components can cause air leakage and the inability of the inlet or outlet quick disconnect to adequately secure the connection hose and supply air hose.

⑥ Mounting the Air Line Kit

When installing the Air Line Kit, securely install the Air Line Kit by mounting it on a flat, level surface. If the Air Line Kit is dropped, damage to the Air Line Kit and injury to the operator is possible.

⑦ Oil Mist Filter Bowl

- The bowl is made of a polycarbonate.

Do not use the Air Line Kit in conditions where chemicals or organic solvents are present in the atmosphere.

- Do not remove the bowl guard. Using the Air Line Kit without the bowl guard may cause injury to the operator should the bowl burst.

- When removing the bowl from the Oil Mist Filter, remove all pressure from the Input and Output sides of the Air Line Kit.

⚠ CAUTION

① Use of dry air

Using compressed air containing excessive moisture could result in malfunction or failure of the air bearing spindle. If excessive moisture or condensation are found in Oil Mist Filter Bowl, it will be necessary to install a dryer and larger Air Filter on the primary side of the Air Line Kit to prevent and remove excessive moisture.

② Draining

Be sure to drain moisture and condensation from Oil Mist Filter Bowl regularly to avoid moisture and oil being carried to the air bearing spindle.

③ Installation Location

Place this Air Line Kit on a flat and level surface.

If mounting on a wall, check if the wall is flat, and securely mount the Air Line Kit in a horizontal direction.

④ Handling

When removing the Bowl for cleaning, carefully remove them as not to cause damage to them.

⚠ CAUTIONS for STORAGE, INSTALLATION and OPERATION

① Do not use the Air Line Kit where corrosive gasses, chemicals, seawater, water, oils or steam exist.

② Do not place in direct sunlight.

③ Do not use where the Air Line Kit is subject to vibration or repetitive shock.

④ Do not use where a heat source or radiated heat exist.

⑤ To conform to " STORAGE, INSTALLATION and OPERATION " (Refer to " 3. SPECIFICATIONS ").

2. FEATURES

- ① This Air Line Kit is designed to supply clean and dry cooling and purging air to air bearing spindle and turbine motor.
- ② The Oil Mist Filter traps small amounts of water, oil and impure substances from the input air supply. This Air Line Kit is not intended to be used or replace an Air Dryer.
- ③ Provides stable air flow and proper air pressure to the air bearing spindle by using an adjustable Regulator.
- ④ Air pressure can be easily adjusted.
- ⑤ This Air Line Kit is wall mountable.

3. SPECIFICATIONS

Model	AL - A1205	
Primary Air Pressure	Less than 1.0MPa	
Secondary Air Pressure	Less than 0.85MPa	
Maximum Operation Pressure	1.0MPa	
Maximum Peak Pressure	Less than 1.5MPa	
Maximum Peak Pressure at Hose Connection	Less than 1.0MPa	
Filtration of the Oil Mist Filter	0.3µm	
Maximum Air Volume Allowed	310Nℓ / min	Primary Side Air Pressure: 0.7MPa Air Pressure Drop : 0.01MPa
Drain Reservoir Capacity	25cm ³	
Safe Pressure Regulator Operating Range	0.05 ~ 0.85MPa	
Pressure Relief	Automatic Relief Valve	
Dimensions	W 300 X D120 X H 266mm	
Weight	2.4kg	
Operation Environment	Temperature	5 ~ 40°C
	Humidity	MAX. 85%
	Atmospheric Pressure	700 ~ 1,060hPa
Transportation and Storage Environment	Temperature	-10 ~ 60°C
	Humidity	10 ~ 80%
	Atmospheric Pressure	500 ~ 1,060hPa

Standard Accessories

- | | |
|--|------------------------------|
| • Connection Hose (2m) • • 1pc. | • Washers • • 4pcs. |
| • Mounting Screws | • Rubber Pads • • 4pcs. |
| (Cross-Recessed Truss Tapping Screw : M6 × 20) • • 4pcs. | • Operation Manual • • 1set. |

4. PARTS NAMES

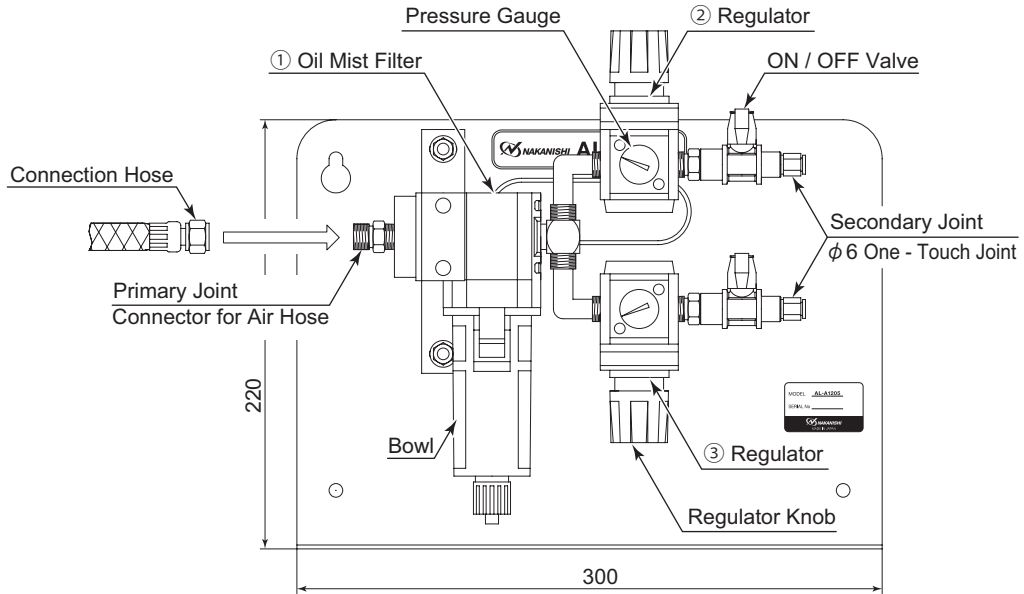

Fig. 1

If the Oil Mist Filter or Regulator are damaged, all components are replaceable by the end-user. (Refer to Table 1 and Table 2).

Table 1.

	Name	Model	Manufacturer
①	Oil Mist Filter Assembly	M2000 - 8 - W - S	CKD
②	Regulator	R1000 - 8 - W - X1	
③	Regulator	R1000 - 8 - W	

Table 2. Oil Mist Filter Replacing Optional

Name	Model	Manufacturer
Oil Mist Filter Consumable Parts Kit (The set includes the O - Ring, Mantle and Bowl O - Ring.)	M2000 - KIT - S	CKD

5. OPERATION

5 - 1 Oil Mist Filter (Fig. 2)

The water, oil, dirt and debris are separated from the compressed air.
The separated debris is collected in the Bowl.

5 - 2 Draining (Fig. 2)

Opening and closing the Drain Valve.
(DO NOT allow liquids and / or debris to exceed the Upper Limit as shown in Fig. 2.)

- O direction : Draining.
- S direction : Stop Draining.

< To divert the drain to another location >
Connect a hose with a ϕ 6mm I.D. (Not included / provided by the end-user.) to the Drain Output Port and divert to another location.

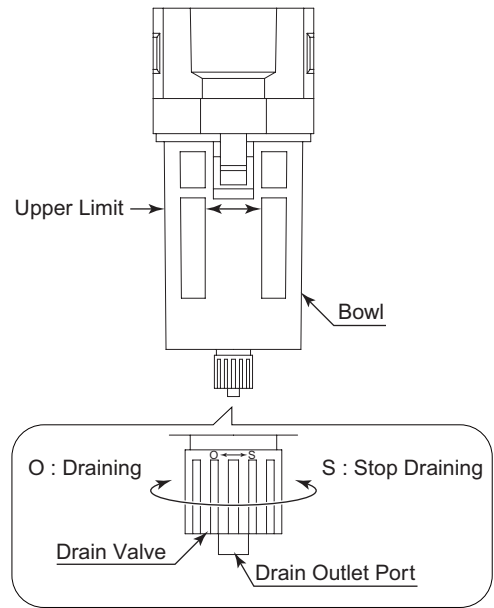

Fig. 2

5 - 3 Regulator (Fig. 3)

< Lock and Release of the Regulator Knob >
Regulator Knob is equipped with Lock mechanism.
Release : Pull the Regulator Knob OUT to unlock.
Lock : Push the Regulator Knob IN to the Lock position.

< Adjusting Air Pressure >
Turn the Regulator Knob while watching Pressure Gauge increase or decrease.
H direction : Air pressure is increased.
L direction : Air pressure is decreased.

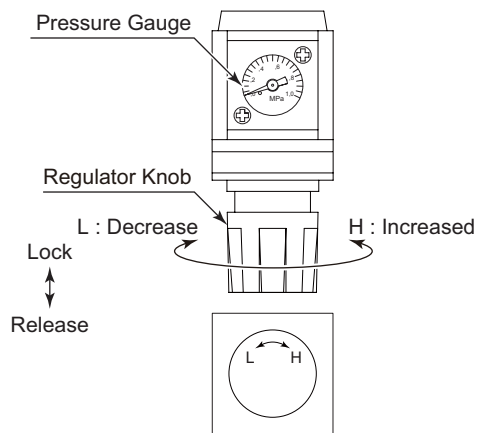

Fig. 3

5 - 4 ON / OFF Valve (Fig. 4)

Turn the ON / OFF Lever located on the valve 90-Degrees to turn the air output ON (Open) or OFF (Close).

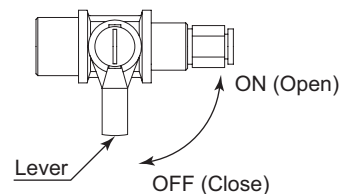

Fig. 4

6. INSTALLATION AND CONNECTION OF THE AIR LINE KIT

⚠ CAUTION

The Air Line Kit install to the horizontal. If "Rear Mounting", install the Air Line Kit to the horizontally on a vertical wall.

6 - 1 Installation of the Air Line Kit

(1) Horizontal Installation

When the Air Line Kit is mounted from the bottom in a horizontal position Affix the Rubber Pads (Standard Accessories : 4pcs.) to the bottom of the Air Line Kit.

(2) Rear Mounting or Bottom Mounting

Attach the Air Line Kit by the Mounting Screws (Cross-Recessed Truss Tapping Screw : M6 × 20) (Standard Accessories : 4pcs) or M6 screw (not included / provided by the end-user) (Fig . 5).

* When Rear Mounting, attach using the Washers (Standard Accessories : 4pcs) between mounting surface and rear surface of the Base Plate with on horizontal attitude.

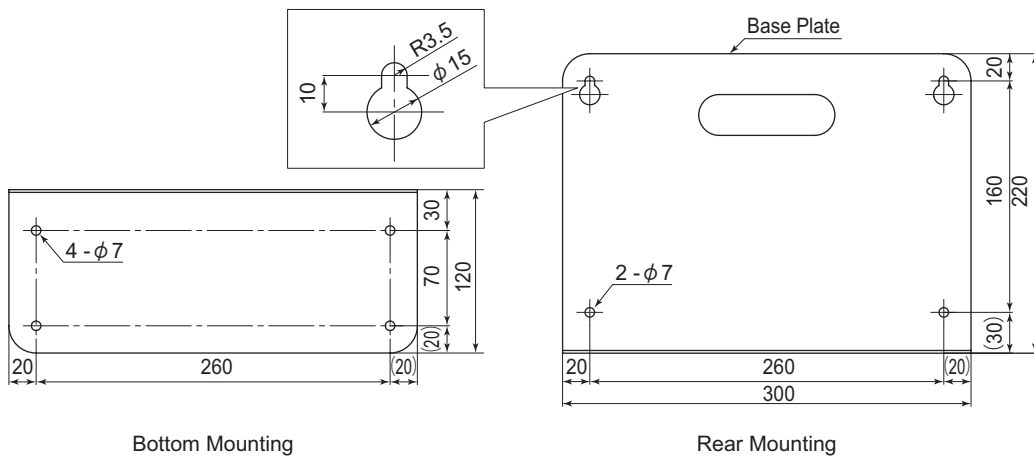

Fig. 5

6 - 2 Connection of the Air Line Kit

(1) Connect the Connection Hose (Standard Accessory) to the Primary Joint of the Air Line Kit.

(2) Connect one supply air hose from the Secondary Joints to the Air Bearing / and one Hose to the Air Turbine (φ6 One - Touch Joint : 2 positions) of the Air Line Kit.

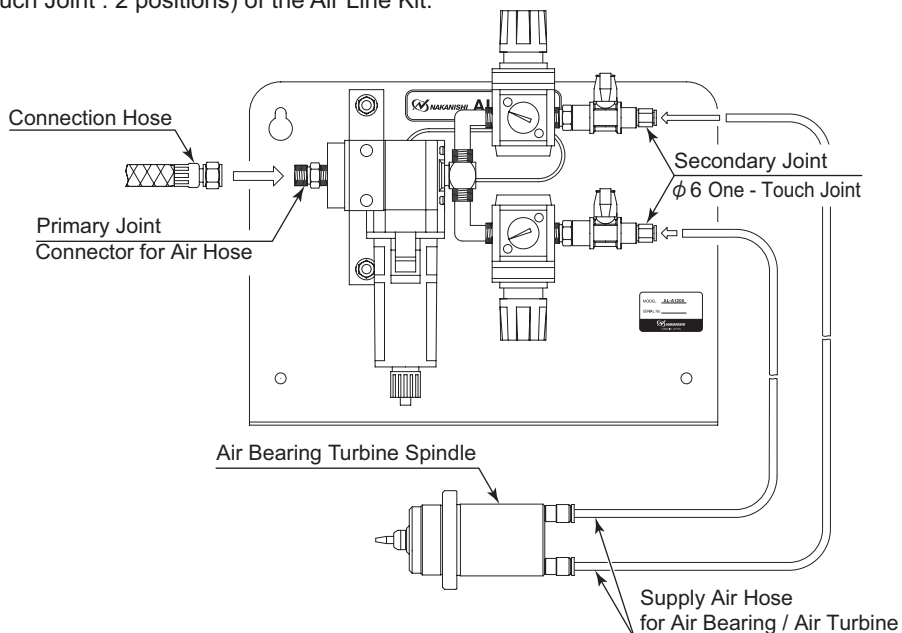

Fig. 6

7. TROUBLESHOOTING

If a problem or concern occur, please check the following items prior to consulting your dealer.

Trouble	Inspection / Corrective Active
Broken connection hose and supply air hose.	Replace the connection hose and supply air hose.
No air flow.	Check the compressor power supply and the air compressor output.
	Check if connection hose and supply air hose is broken, bent or disconnected.
	Check the Regulator and set to the correct air pressure. Check all connection hose and supply air hose connections.
	ON / OFF Valve is OFF position. The ON / OFF valve set to ON position.
Air leakage.	Check all threaded joints and re-tighten if necessary.
Low air pressure.	Check the Compressor, Air Circuit, and Regulator.
Water, oil, dirt and debris are collected in the Oil Mist Filter Bowl.	Drain water, oil, and remove dirt and debris from the Oil Mist Filter bowl.

8. DISPOSAL OF THE AIR LINE KIT

When disposal of an Air Line Kit is necessary, follow the instructions from your local government agency for proper disposal of industrial components.

※仕様及び形状等は予告なく変更する場合がありますので、ご了承ください。

株式会社 **ナカニシ** www.nakanishi-inc.com

本社・工場

〒322-8666 栃木県鹿沼市下日向 700
TEL: 0289(64)3380 FAX: 0289(62)5636

東京事務所

〒110-0015 東京都台東区東上野 4-8-1 TIXTOWER UENO 9F
TEL: 03(5828)7740 FAX: 03(5828)0064

※Specifications may be changed without notice.

NAKANISHI INC.  www.nakanishi-inc.com
700 Shimohinata Kanuma-shi Tochigi 322-8666, Japan

NSK Europe GmbH  www.nsk-europe.de
Elly-Beinhorn-Strasse 8 65760 Eschborn, Germany

NSK America Corp www.nskamericacorp.com
1800 Global Parkway Hoffman Estates, IL 60192, USA